

# Sagemcom



## Siconia® WATER SM

A solution for efficient remote management of cold or hot water consumption for water companies

The use of an **ultrasonic metrology technology** allows to eliminate all mechanical moving parts inside the meter and therefore no longer have any mechanical wear phenomenon that would modify the quality of the metrology over time.

Siconia® technology offers a wide range of ultrasonic smart water meters to control, monitor and manage water use in **residential and industrial** environments.

The Siconia® Water metrological unit offers a wide range of measurements, with very high accuracy and a metering **error very close to 0%**. As it remains stable throughout the life of the meter, the information on the water distribution is reliable and the water balance of the network **can be checked daily**, making it **easier to detect leaks** in the network pipes.

## Technical features

### METROLOGY

- Nominal diameter (mm): DN15
- Nominal flow rate: Q3 (m<sup>3</sup>/h): 2,5
- Minimum flow rate: from 2 l/h
- MID accuracy ratio (Q3/Q1): R250, R400
- Class 2
- Nominal pressure: 16 bars
- Class of T°: T30, T70 (R250)
- Measuring frequency: up to 8 Hz
- Mounting in any position (H, V, H/V)
- Sensitive class: U0/D0
- Pipe in brass or composite: 110 mm

### TECHNICAL CERTIFICATIONS

- EC
- EN14154
- EN 4064
- MID, OIML-R49
- AFNOR E17-901

### DRINKING WATER CERTIFICATIONS

- All materials are from 4MS list
- WRAS
- ACS
- DM174
- SVGW
- RISE
- HYDROCHECK

### COMMUNICATION



- Data logger (36 months capacity)
- Data security (AES128 encryption)

### EDGE ADVANCED COMPUTING SERVICES

- Leak detection
- Anti-forgery logs and alarms
- Water quality management - backflow detection

### USAGE

- Ultrasonic meter for residential and industrial use

### ENERGY

- Lithium battery
- Up to 12 years lifetime\*

### ENVIRONMENT

- Protection class IP54
- Humidity: 98%
- Ambient temperature 0 - 65°C

\*Depends on radio configuration, associated data model and environmental conditions

## Dimensions

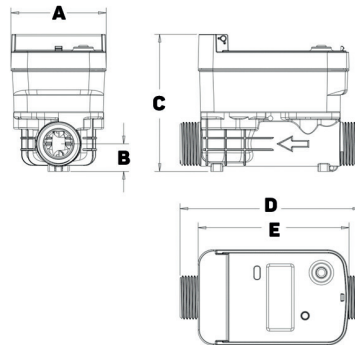

Siconia® SM	
Q3 = 2,5 m <sup>3</sup> /h	
Connexion 3/4"	
A (mm)	58
B (mm)	14
C (mm)	80.6
D (mm)	110
E (mm)	92.6

## Typical error and pressure loss

Typical metrological curve - R250

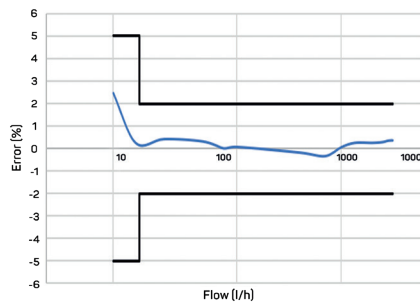

Typical pressure loss curve - R250

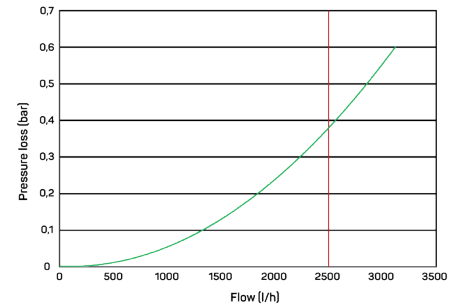

## LCD Interface

The complete range of Siconia® Water SM meters offers an LCD display. With its ten digits (7+3), it is well above the requirements of the MID specification.

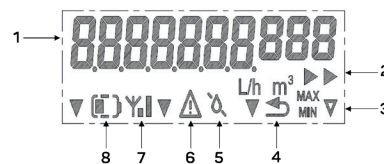

1	The measured volumes are indicated in m <sup>3</sup> , associated with 3 decimal places giving an indication in liters
2	Animated icons showing when there is an active flow through the meter
3	MID certified information
4	The counter is in a backflow situation
5	The water line is not filled with water
6	One or more events/alarms are currently active
7	RF status information
8	Battery level information

All rights reserved. The information and specifications included are subject to change without prior notice. Sagemcom Energy & Telecom tries to ensure that all information in this document is correct, but does not accept liability for error or omission. Non contractual document. All trademarks are registered by their respective owners. Simplified joint stock company Capital 25 605 811.80 Euros - 518 250 337 RCS Nanterre. 06/2021

## Sagemcom Energy & Telecom SAS

Headquarters : 250, route de l'Empereur  
92848 Rueil-Malmaison Cedex - FRANCE

Tel : +33 (0)1 57 61 10 00 - Fax : +33 (0)1 57 61 10 01

www.sagemcom.com

# Sagemcom